

# riaa Equalized Stereo Phono Preamp

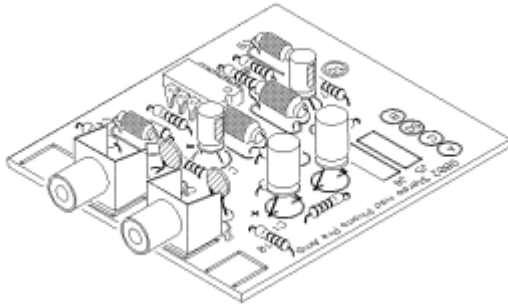

This riaa Pre-Amp is the perfect solution to getting a signal off of your old turntable and into your mixing board. Whether you want to grab a couple of loops from a 70's LP record or just archive your record collection you need an riaa compensated pre-amp to do it. When grooves are cut in the vinyl of a record pre-emphasis is used to even out the size of the high and low frequency grooves. To restore the recovered signals frequency response, de-emphasis is required and this is the function of the PAiA riaa pre-amp.



The FRM accessory kit adds [1W FracRak](#) card cage format panel and power connector

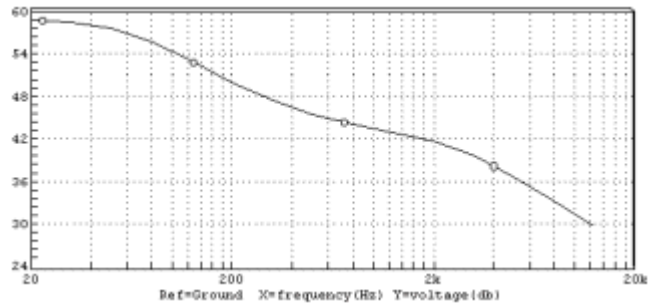

The frequency response curve of the 9802 Stereo Phone-Pre conforms to the Recording Industry Association of America (riaa) standard .

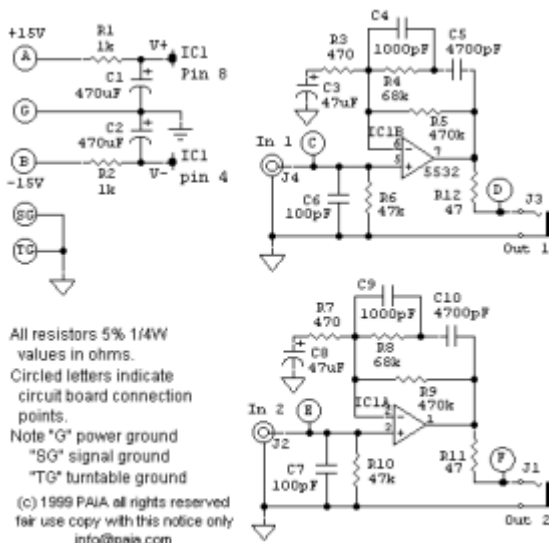

RIAA Compensated Stereo Phono Preamp Schematic

As shown in the schematic, the circuit is built around an NE5532 high performance dual operational amplifier set up in a non-inverting configuration. Let's look at one channel and see how it works. R5 and R3 initially give the pre-amp about 60db of gain. However R3 and C3 roll off low frequencies and form a rumble filter. The network of R4/C4 and R5/C5 actually form the riaa equalization response. Power is isolated by R1/R2 and filtered by



C1/C2. The Phono Pre can run from a pair of 9V batteries or our [9770R-12 Universal Power Supply](#).

**9802k Stereo riaa Phono Preamp kit** includes all electronic parts, circuit board, pc mount phono jacks and 1/4" phone jacks for outputs ..... us\$23.75 (4.00)

**9802frm FracRak Accessory Kit** includes punched, black anodized and grey legended 1W FracRak panel, FracRak standard power connector and all hardware ..... us\$12.25 (4.00)